

# Montage & Bedienungsanleitung Assembly & Operating Instructions



## Leuchtenträger / Light-System

Beleuchtung für Trägersysteme  
Light for Carrier Systems



DE	Montageanleitung
EN	Assembly Instructions
FR	Instructions de montage
IT	Istruzioni di montaggio
NL	Montage-instructies
DA	Monteringsvejledning
SE	Monteringsanvisningar
ES	Instrucciones de montaje
PL	Instrukcja montażu
RU	Инструкции по сборке
CZ	Montážní návod
SI	Navodila za montažo
GR	Οδηγίες συναρμολόγησης

1889446

(© 2025 ALOIS KOBER GMBH, Germany)

01/2025

This documentation - or excerpts thereof - may only be copied or made accessible to third parties with the express permission of the ALOIS KOBER GMBH. We reserve the right to make functional modifications to reflect technological advances.

# 1.0 / 1750mm



Nr.	Name	Stk. / Pcs.	Art.
1	Kennzeichen Sawiko ALKO.par:1	1	Kein Lieferumfang
2	1887865 Leuchenträgerblech FT230-Light - Kurz - V2.psm:1	1	1887865
3	1885187 SAWIKO Gel Aufkleber.par:1	1	1885187
4	1885104 Bohrschraube DIN 7504 - 4,8X13 - Schwarz.par:3	4	1885104
5	1887866 Abdeckung - kurz - V2.psm:1	1	1887866
6	107320 Verschlusskappe.par:1	1	Teil vom Kabel
7	1885646 Abdeckkappe 4,8X14,1X7 TPG - Schwarz.par:8	8	1885646
8	Lamellenstopfen Rechteck 60x30 1-3.par:2	2	1888393
9	1885652 - BLINDNIET 4,8 X 12 - Multigrip.par:6	7	1885652
10	1887705 FT-230 LED - RÜCK.par:1	1	1887705
11	1887706 FT-230 LED - NEBEL.par:1	1	1887706

Var: "A"

LED

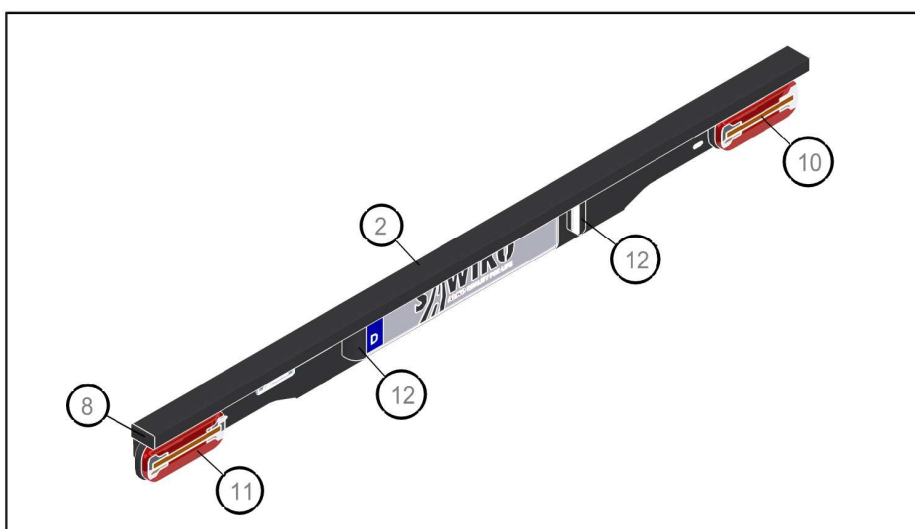

Nr.	Name	Stk. / Pcs.	Art.
1	Kennzeichen Sawiko ALKO.par:1	1	Kein Lieferumfang
2	1887865 Leuchenträgerblech FT230-Light - Kurz - V2.psm:1	1	1887865
3	1885187 SAWIKO Gel Aufkleber.par:1	1	1885187
4	1885104 Bohrschraube DIN 7504 - 4,8X13 - Schwarz.par:3	4	1885104
5	1887866 Abdeckung - kurz - V2.psm:1	1	1887866
6	107320 Verschlusskappe.par:1	1	Teil vom Kabel
7	1885646 Abdeckkappe 4,8X14,1X7 TPG - Schwarz.par:8	8	1885646
8	Lamellenstopfen Rechteck 60x30 1-3.par:2	2	1888393
9	1885652 - BLINDNIET 4,8 X 12 - Multigrip.par:6	7	1885652
10	Rückleuchte Delta rechts.par:1	1	1628368
11	1887883 LED Kennzeichenleuchte - FASA.par:1	2	1887883

Var: "B"

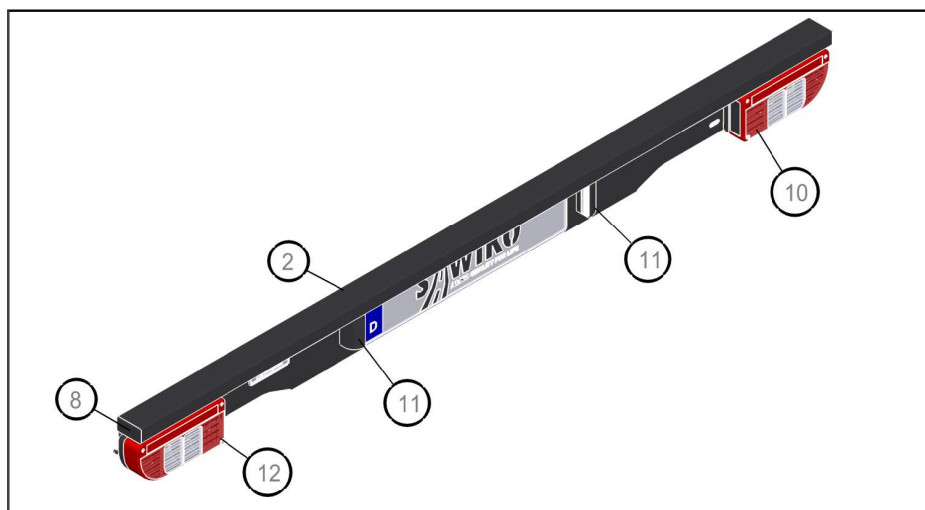

# 2.0 / 1950mm



**Var: "A"**  
**LED-SJL**

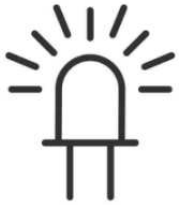

Pos.	Anzahl	Artikel Nr.:	Bezeichnung
7	8	703163	Scheibe DIN 125-8,4-A1
8	4	706224	Sechskantmutter DIN 985-M8xSW13
9	4	706206	Sechskantschraube DIN 933 M8x20
10	4	1888082	SW 13-2-G 10
11	2	700147	Scheibe DIN 9021-5,3-140HV
12	2	700119	Sechskantmutter DIN 985-M5xSW8
20	2	1889008	1889008 Adapter Variabel
23	4	1888083	SW 13-2-G 14
26	2	706172	Flachrundschaube DIN 603-M6x16 - schwarz
27	2	700148	Scheibe DIN 9021-6,4-140HV
28	2	706223	Sechskantmutter DIN 985-M6xSW10

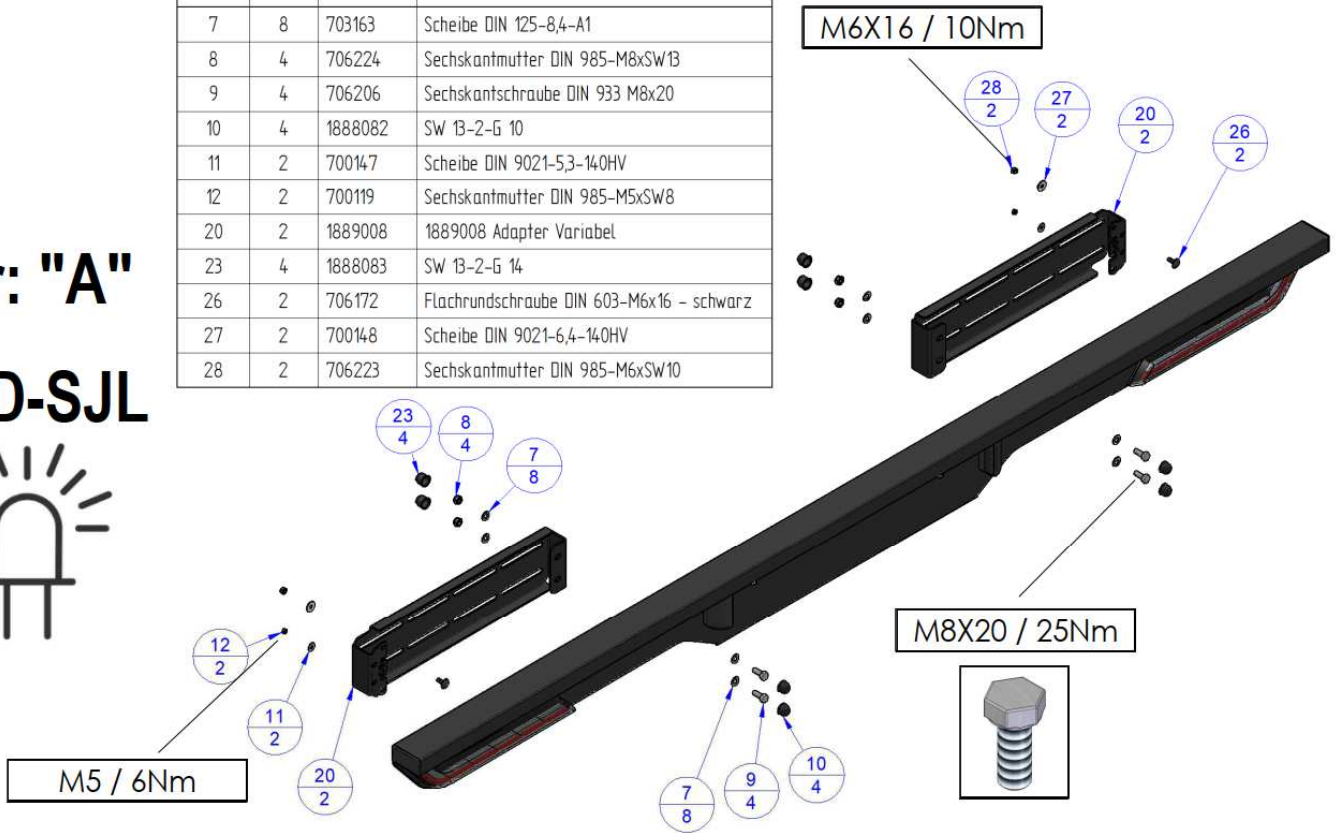

Pos.	Anzahl	Artikel Nr.:	Bezeichnung
14	4	1883165	1883165 Adapter
15	16	703163	Scheibe DIN 125-8,4-A1
16	8	706224	Sechskantmutter DIN 985-M8xSW13
17	8	706206	Sechskantschraube DIN 933 M8x20
18	8	1888082	SW 13-2-G 10

**Var: "B"**

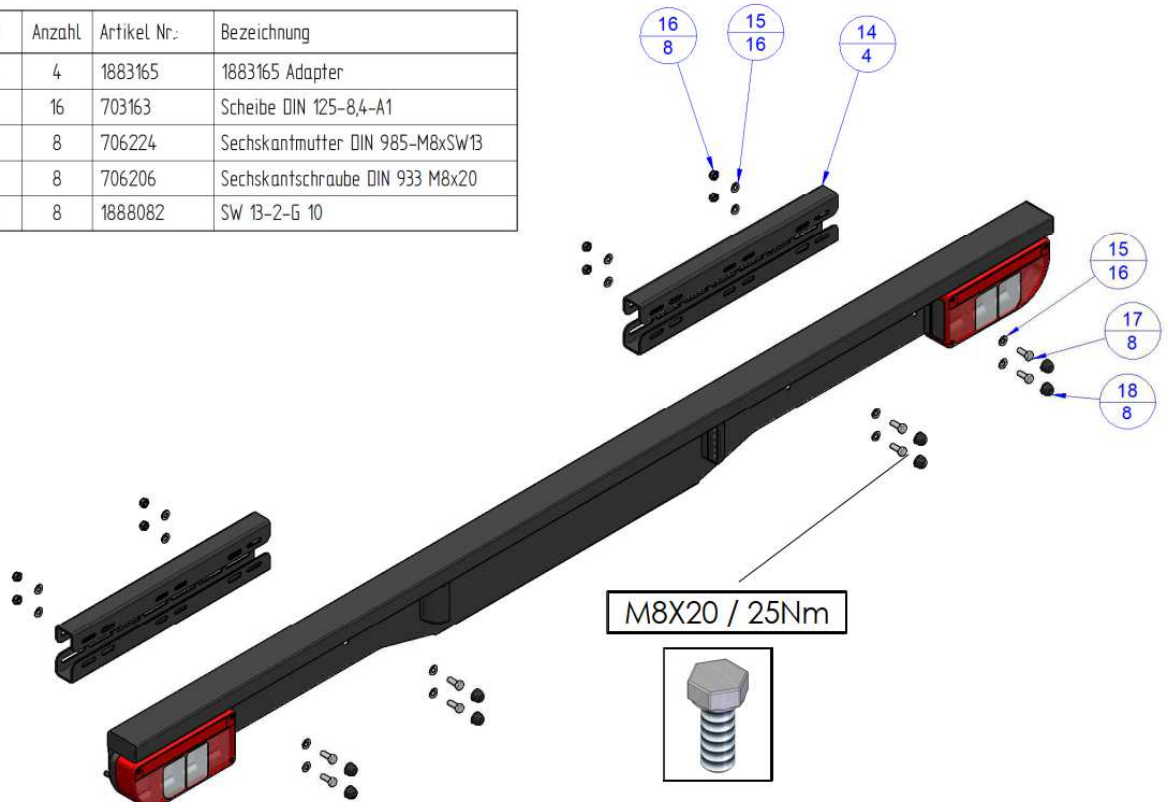

# 2.1 LED - SJL



Pos.	Anzahl	Artikel Nr.	Bezeichnung
1	1	1883153	1883153 Leuchtenträgerblech SJL
2	2	1887883	1887883 LED Kennzeichenleuchte - FASA
5	1	1889025	1889025 Abdeckung - Breit SJL
6	2	1888393	Lamellenstopfen Rechteck 60x30 1-3
7	8	703163	Scheibe DIN 125-8,4-A1
8	4	706224	Sechskantmutter DIN 985-M8xSW13
9	4	706206	Sechskantschraube DIN 933 M8x20
10	4	1888082	SW 13-2-G 10
11	6	700147	Scheibe DIN 9021-5,3-140HV
12	6	700119	Sechskantmutter DIN 985-M5xSW8
13	6	1885646	1885646 Abdeckkappe 4,8X14,1X7 TPG - Schwarz
14	1	1883154	1883154 Rückleuchte - SJL - LINKS
15	1	1883155	1883155 Rückleuchte - SJL - RECHTS
16	1	1889026	HELLA Reflektor Shapeline 8RA - ROT - Links
17	1	1889027	HELLA Reflektor Shapeline 8RA - ROT - Rechts
20	2	1889008	1889008 Adapter Variabel
22	4	1885104	1885104 Bohrschraube DIN 7504 - 4,8X13 - Schwarz
23	4	1888083	SW 13-2-G 14
26	2	706172	Flachrundschraube DIN 603-M6x16 - schwarz
27	2	700148	Scheibe DIN 9021-6,4-140HV
28	2	706223	Sechskantmutter DIN 985-M6xSW10
29	7	1885652	1885652 - BLINDNIET 4,8 X 12 - Multigrip

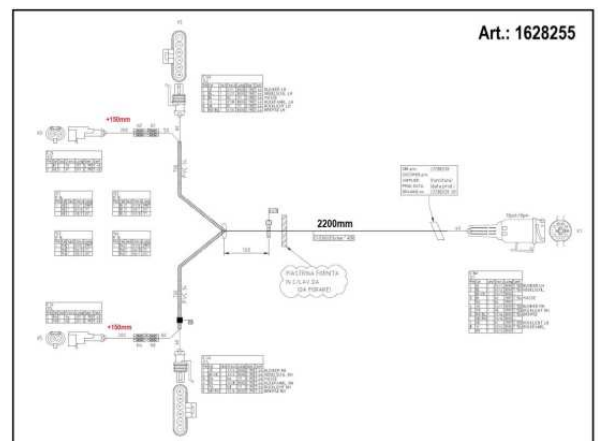
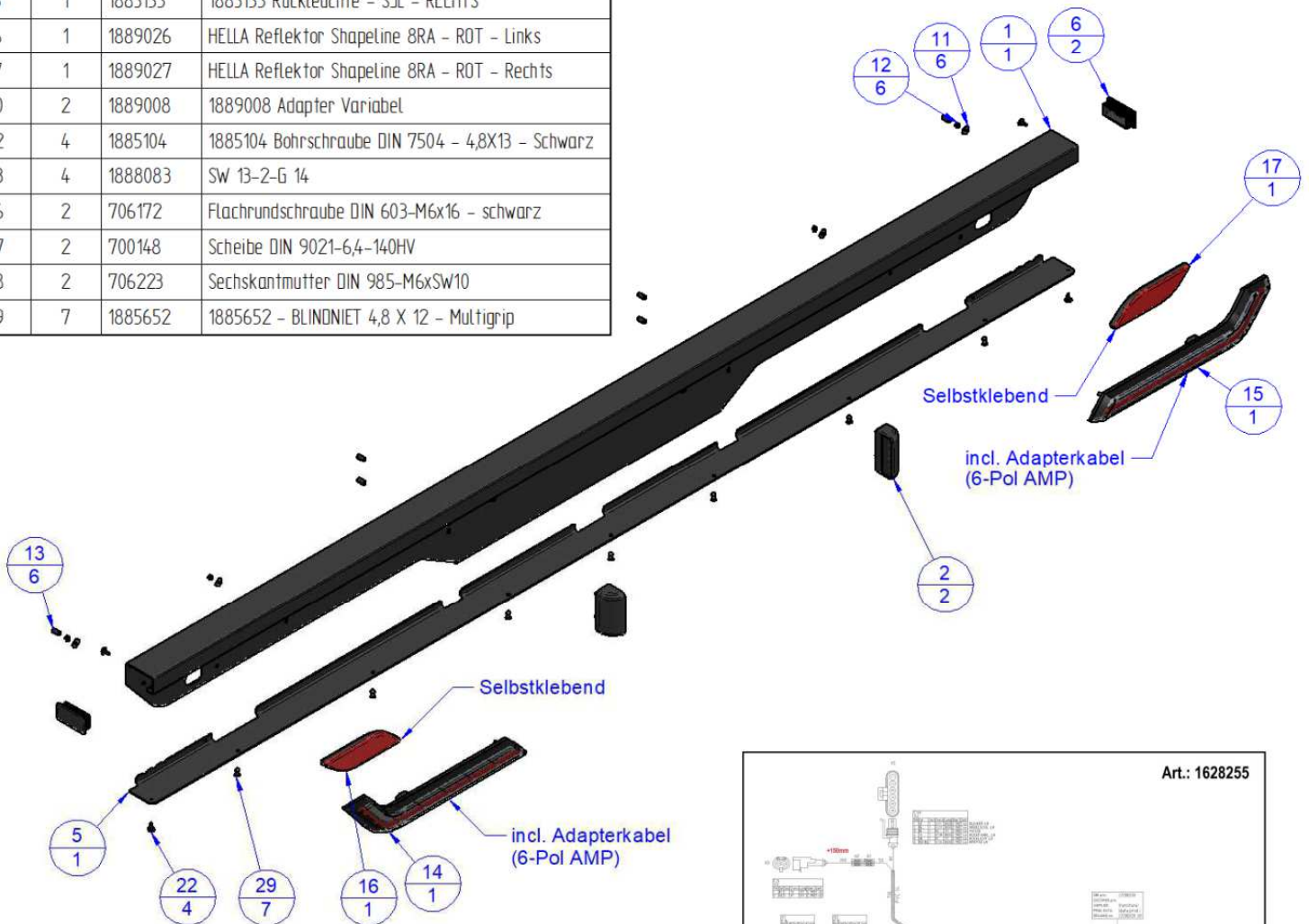

# 2.2

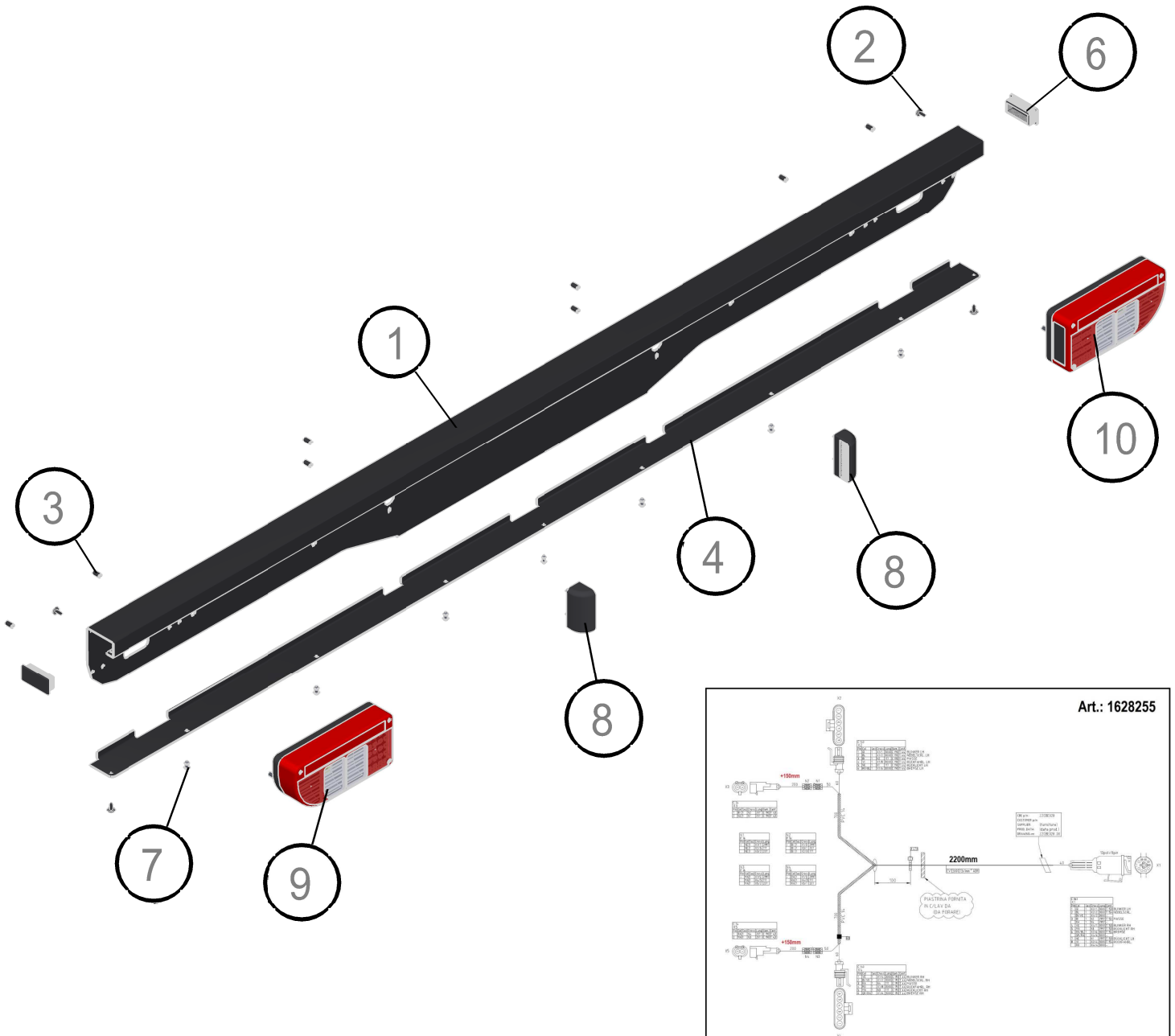
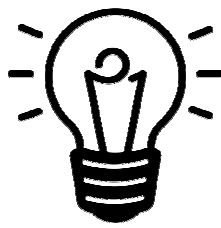

Nr	Name	Stk. / Pcs.	Art.:
1	1888783 Leuchtenträgerblech FT230-Light -Breit.psm:1	1	1888783
2	1885104 Bohrschraube DIN 7504 - 4,8X13 - Schwarz.par:3	4	1885104
3	1885646 Abdeckkappe 4,8X14,1X7 TPG - Schwarz.par:9	8	1885646
4	1888784 Abdeckung - Breit.psm:1	1	1888784
5	107320 Verschlusskappe.par:1	1	Teil vom Kabel
6	Lamellenstopfen Rechteck 60x30 1-3.par:2	2	1888393
7	1885652 - BLINDNIET 4,8 X 12 - Multigrip.par:6	7	1885652
8	1887883 LED Kennzeichenleuchte - FASA.par:1	2	1887883
9	Rückleuchte Delta links.par:1	1	1628369

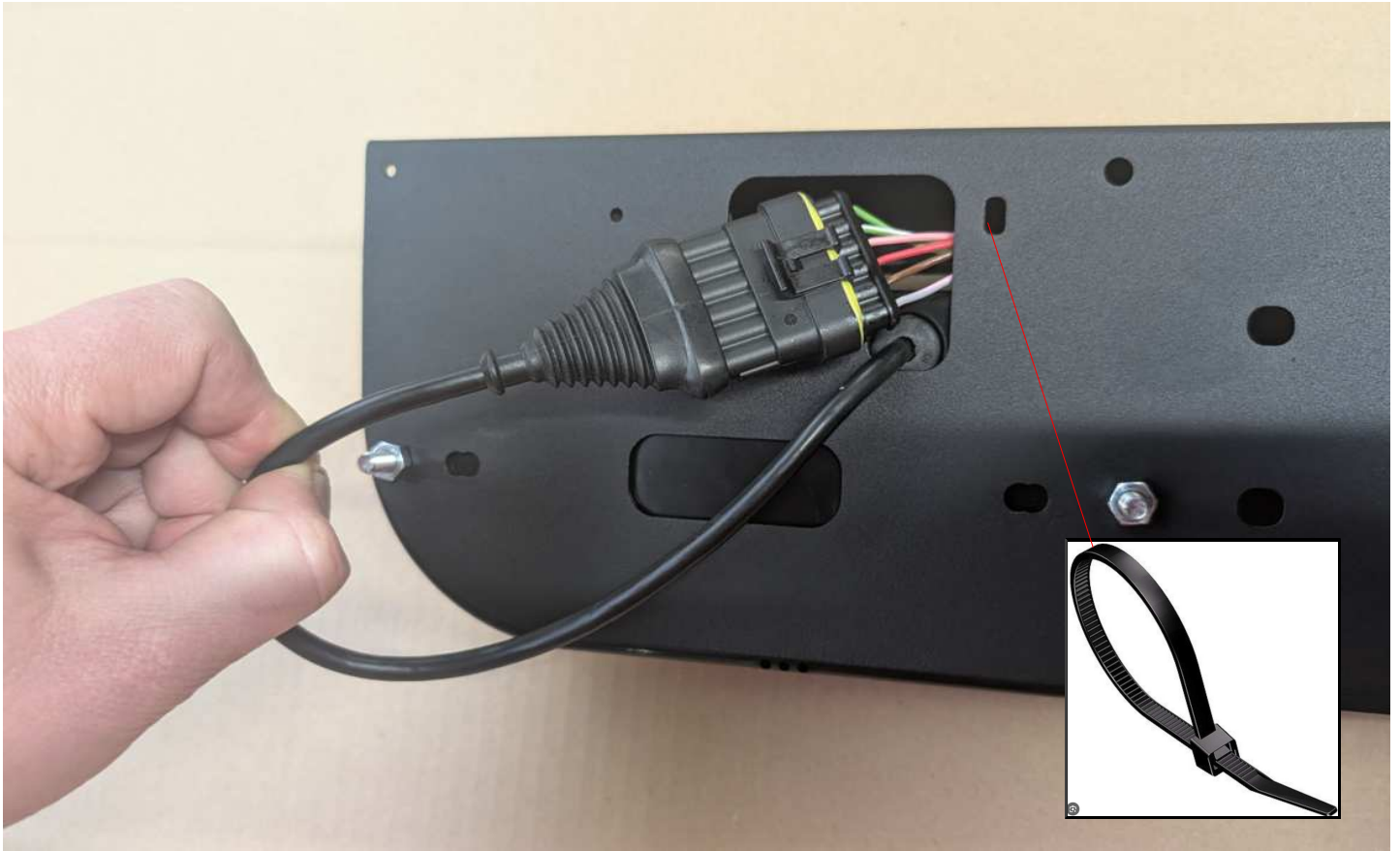

# 4.1

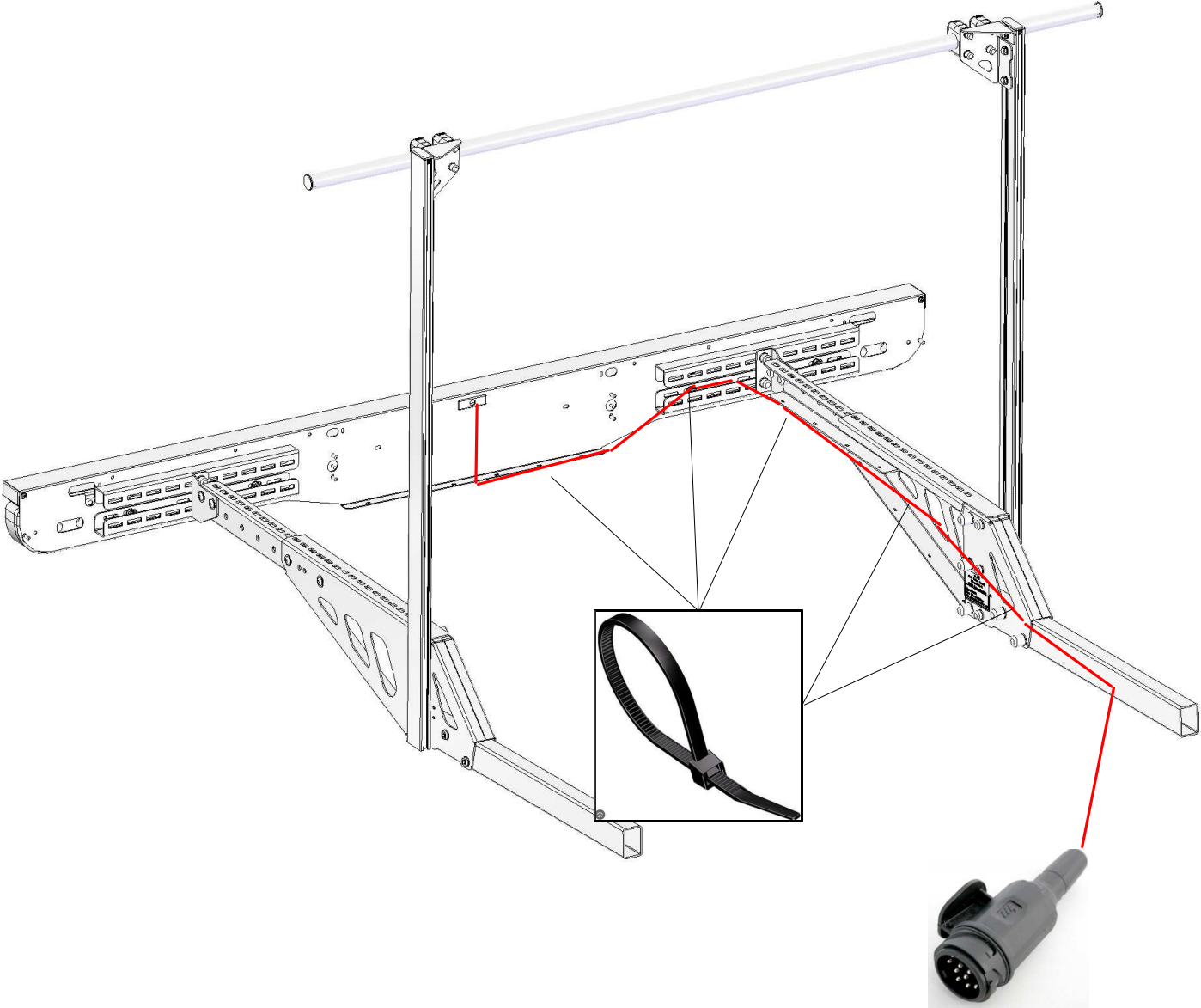



---

Alois Kober GmbH

Ringstraße 3

49434 Neuenkirchen

Service Telefon : (+49) 0 54 93 - 99 22 0

---

## TYP: Leuchenträger

---

- DE) Änderungen, die dem technischen Fortschritt dienen, vorbehalten. Die Haftung für Irrtümer und Druckfehler ausgeschlossen. Abbildungen können abweichen.
- EN) We reserve the right to make changes that serve technical progress. Liability for errors and misprints is excluded. Illustrations may vary.
- FR) Nous nous réservons le droit d'apporter des modifications qui servent le progrès technique. La responsabilité pour les erreurs et les fautes d'impression est exclue. Les illustrations peuvent varier.
- IT) Ci riserviamo il diritto di apportare modifiche che servano al progresso tecnico. È esclusa la responsabilità per errori e refusi. Le illustrazioni possono variare.
- NL) We behouden ons het recht voor om wijzigingen aan te brengen die de technische vooruitgang dienen. Aansprakelijkheid voor fouten en drukfouten is uitgesloten. Illustraties kunnen variëren.
- DA) Vi forbeholder os ret til at foretage ændringer, der tjener den tekniske udvikling. Ansvar for fejl og trykfejl er udelukket. Illustrationer kan variere.
- SE) Vi förbehåller oss rätten att göra ändringar som tjänar den tekniska utvecklingen. Ansvar för fel och tryckfel är uteslutet. Illustrationerna kan variera.
- ES) Nos reservamos el derecho de realizar cambios que sirvan al progreso técnico. Se excluye la responsabilidad por errores y erratas. Las ilustraciones pueden variar.
- PL) Zastrzegamy sobie prawo do wprowadzania zmian, które służą postępowi technicznemu. Odpowiedzialność za błędy i pomyłki drukarskie jest wykluczona. Ilustracje mogą się różnić.
- RU) Мы оставляем за собой право вносить изменения, которые служат техническому прогрессу. Ответственность за ошибки и опечатки исключена. Иллюстрации могут отличаться.
- CZ) Vyhrazujeme si právo provádět změny, které slouží technickému pokroku. Odpovědnost za chyby a tiskové chyby je vyloučena. Ilustrace se mohou lišit.
- SI) Pridržujemo si pravico do sprememb, ki služijo tehničnemu napredku. Odgovornost za napake in napačne odtise je izključena. Ilustracije se lahko razlikujejo.
- GR) Διατηρούμε το δικαίωμα να κάνουμε αλλαγές που εξυπηρετούν την τεχνική πρόοδο. Η ευθύνη για σφάλματα και λανθασμένες εκτυπώσεις αποκλείεται. Οι εικόνες ενδέχεται να διαφέρουν.